

JUST Solar

Version: V1.1



*Global Installation Manual for
Just Solar Co., Limited
Photovoltaic Module*

CONTENTS

- Purpose of this manual** 02
- Disclaimer** 02
- Safety and Transport** 03
- Mechanical Installation** 04
- Electrical Installation** 10
- Grounding** 11
- Bypass Diodes and Block Diodes** 12
- Maintenance** 13

Purpose of this manual

- This manual is used for Just Solar Co., Limited(hereinafter referred to as JUSTSOLAR) solar modules (hereinafter referred to as the Module or Modules) only. This manual contains installation methods, operation safety and relevant maintenance information of JUSTSOLAR's Modules.
- Modules must be installed by professionals. Please read this manual carefully before installation. The installers must follow all the rules described in this manual strictly as well as local requirements and regulations by law or authorized organizations .
- Before installing, the installer must be familiar with their mechanical and electrical requirements. Please keep this manual in a safe place for future reference (care and maintenance) and in case of sale or disposal of the Modules .

Disclaimer

- JUSTSOLAR shall not be responsible for any loss arising from installation, operation, use or maintenance of the Modules which is not complying with the guidance of this manual, including breakdown or damage of the Modules or any other expenses incurred.
- Any customer shall not get any patent or authorization of the patent when using the Modules, expressed or implied. Any infringement of patents or other rights of the third party, which may result from the use of the Module, is not within the responsibility scope of JUSTSOLAR.
- The information in this manual is based on JUSTSOLAR's knowledge and experience and is believed to be reliable, but such information including product specification (without limitation) and relevant suggestions do not constitute a warranty, expressed or implied.
- JUSTSOLAR reserves the rights to change the manual, the Modules, the specifications or any other information of the Modules without prior notice.

SAFETY&TRANSPORT

Unpacking and Storage

- Keep all the Modules and electrical connectors clean and dry before installation.
- Use dry and ventilated room when storing uninstalled modules.
- Use both hands to carry Modules. Do not overlap Modules.
- Be cautious when carrying Modules. Slip-proof gloves are necessary.
- Use supportive disassembling tools when unpacking .



Do not stamp on Modules or put weight on Modules.



Do not disassemble or drop Modules.



Do not use mirrors or magnifiers concentrated sunlight onto Modules.



Do not lift the module by grasping the junction box.



Do not use any sharp object with Modules.



Do not directly apply pressure on the glass surface or backsheet of Modules. Must use both hands to carry Modules.



Do not touch the surface of the coated glass with bare hands.



Ensure all contacts and the operating environment are clean and dry.

Modules Carry and Installation Instruction

Both hands when handling Modules	Ensure Modules are fixed properly	Do not use sharp objects with Modules	Do not pulling the wiring cables or junction box
Do not stamp on Modules	Do not touch Modules with bare or dirty hands	Do not pile up Modules on uneven ground	Do not drop or throw Modules

MECHANICAL INSTALLATION

Location Selection

- Select suitable places to install Modules.
- Install Modules at the places with sufficient sunlight and without shade at any time. If a module is shaded or even partially shaded, it will result in lower power output. A permanent or regular shade will cause damage to the module, which will void JUSTSOLAR's warranty.
- Do not place, install or use Modules at the places where combustible gas is easily generated or gathering.
- The straight-line distance between the installation site and coastline shall not be shorter than 1 km unless there is a written approval from JUSTSOLAR or an engagement specified in the contract.

Installation Angle

- Modules in the same string should be installed at the same angle. Modules installed in different angles will receive different irradiation, which will cause current different. As a result, it will decrease the operation efficiency of the system.
- Please refer to Table 1 for the recommended installation angles of the Modules.

Local Latitude	Module installation angle
0°~ 15°	15°
15°~ 25°	Latitude
25°~ 30°	Latitude+5°
30°~ 35°	Latitude+10°
35°~ 40°	Latitude+15°
>40°	Latitude+20°

Table 1

Module Installation

General Installation

- The mounting structure must be made of durable, corrosion-resistant and UV-resistant materials. Always use a tested and certified mounting structure for the system.
- Make sure Modules are securely fastened to the mounting structure to withstand corresponding wind load and snow load.
- Select a suitable height for the mounting system to prevent the lowest portion of the Module covered by snow in winter. In addition, ensure the bottom of the Module is high enough so that the Module will not be shaded by plants or damaged by flying sands.
- As for the system installed on the ground, the minimum distance JUSTSOLAR recommends between the bottom of Modules and the ground should be 24 inches (60 cm).
- Before installing Modules onto a rooftop, make sure the roof construction is suitable and the installed Modules will not exceed the roof area. Besides, the roof must be properly sealed to prevent leaks.
- When installing Modules to a pole, the selected mounting structure and pole shall be able to withstand the expected wind load and snow load in the area.
- Make sure Modules are not subject to wind or snow loads exceeding the maximum load permitted by JUSTSOLAR and not subjected to excessive force due to the thermal expansion of the mounting system. It is not allowed to overlap the Modules.
- Provide adequate ventilation to the back of the Module for cooling. A minimum distance of 10cm between the installation surface and the Module is JUSTSOLAR generally recommended.
- To prevent the linear thermal expansion of the Module frames, JUSTSOLAR suggests that the minimum distance between two Modules should not be shorter than 2cm.
- Always follow the guidance and safety rules specified in the mounting system.
- Do not drill holes on the glass surface or the frames of the Module, which will void the warranty.

Installation Method

Modules can be installed on the frame in the following 3 methods.

- **Mounting hole system:** Use anticorrosive M8 bolts to install the Module on the support frame through the installation holes on its own frame, as shown in Figure 1.

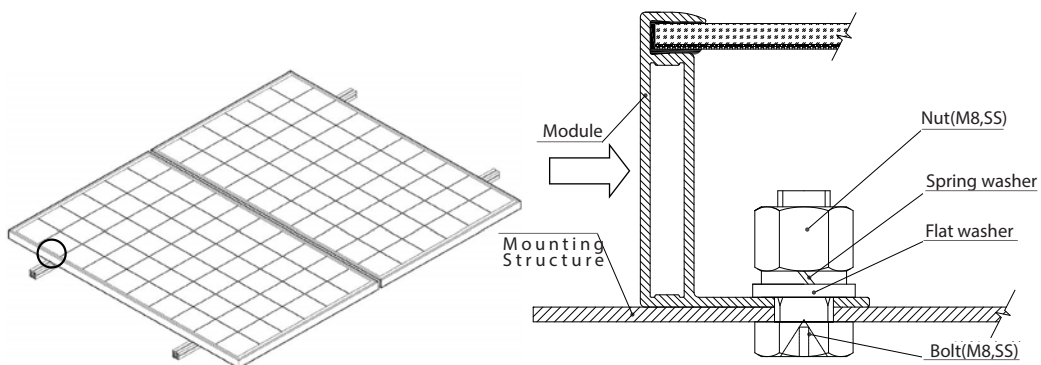

Figure 1

- **Clamping system:** Use suitable clamps to fix the Module on the support frame, as shown in Figure 2.

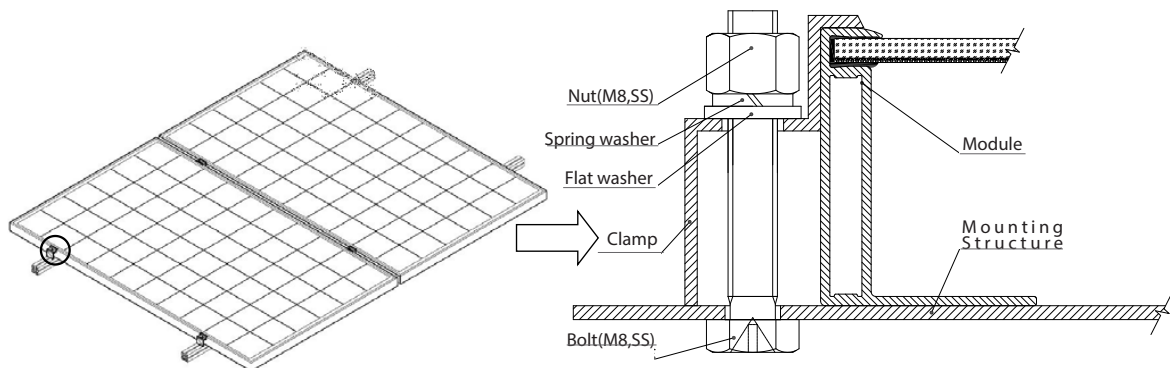

Figure 2

Insertion system: Insert the whole Module into the rail, as shown in Figure 3.

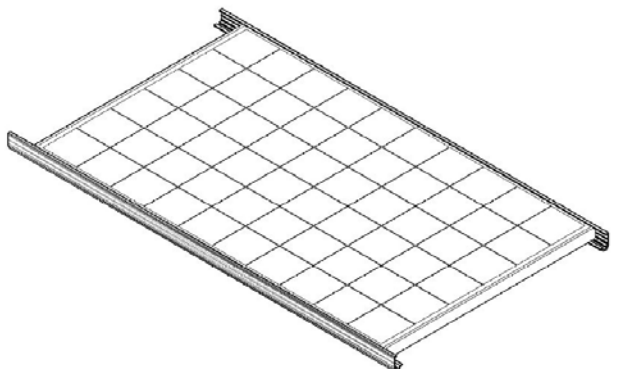
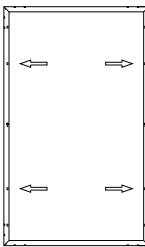
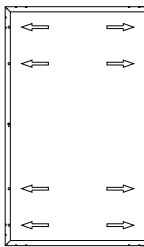
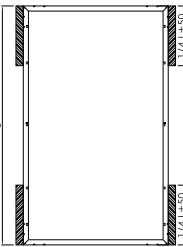
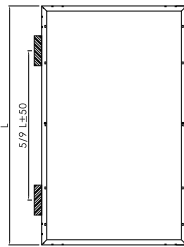
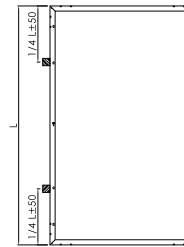
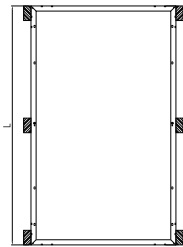
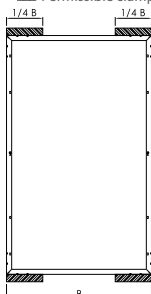
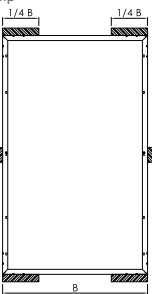
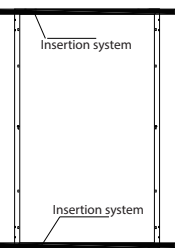
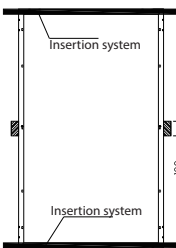

Figure 3

- Select a suitable installation method depending on the load requirements. More detailed information is shown in Figure 4.
- It has been tested that JUSTSOLAR's Modules can withstand the loads of 2400 Pa, 3800 Pa and 5400 Pa (IEC 61215 Standard), which are respectively equivalent to 1600 Pa (0.232 psi), 2500 Pa (0.363 psi) and 3600 Pa (0.522 psi) under UL1703 Standard, when different installation methods are used.

	2400Pa	3800Pa	5400Pa (Snow Loads Only)	
Mounting hole system	1/1	1/2  Use 4 mounting holes	1/3  Use 8 mounting holes	
Clamping system Attachment to the long frame	2/1  Use 4 mounting clips	2/2  Use 4 mounting clips	2/3  Use 4 mounting clips	2/4  Use 6 mounting clips
Clamping system Attachment to the short frame	3/1  Use 4 mounting clips	3/2	3/3  Use 4 mounting clips on short frame Use 2 mounting clips on long frame	
Insertion system	4/1 	4/2	4/3 	

	2400Pa	3800Pa	5400Pa (Snow Loads Only)	
Mounting hole system	5/1	5/2 Use 4 mounting holes	5/3 Use 8 mounting holes	
Clamping system Attachment to the long frame	6/1 Use 4 mounting clips	6/2 Use 4 mounting clips	6/3 Use 4 mounting clips	6/4 Use 6 mounting clips孔
Clamping system Attachment to the short frame	7/1 Use 4 mounting clips	7/2	7/3 Use 4 mounting clips on short frame Use 2 mounting clips on long frame	
Insertion system	8/1	8/2	8/3 Insertion system Insertion system	

Figure 4

- Module Structure (as shown in Figure 5)

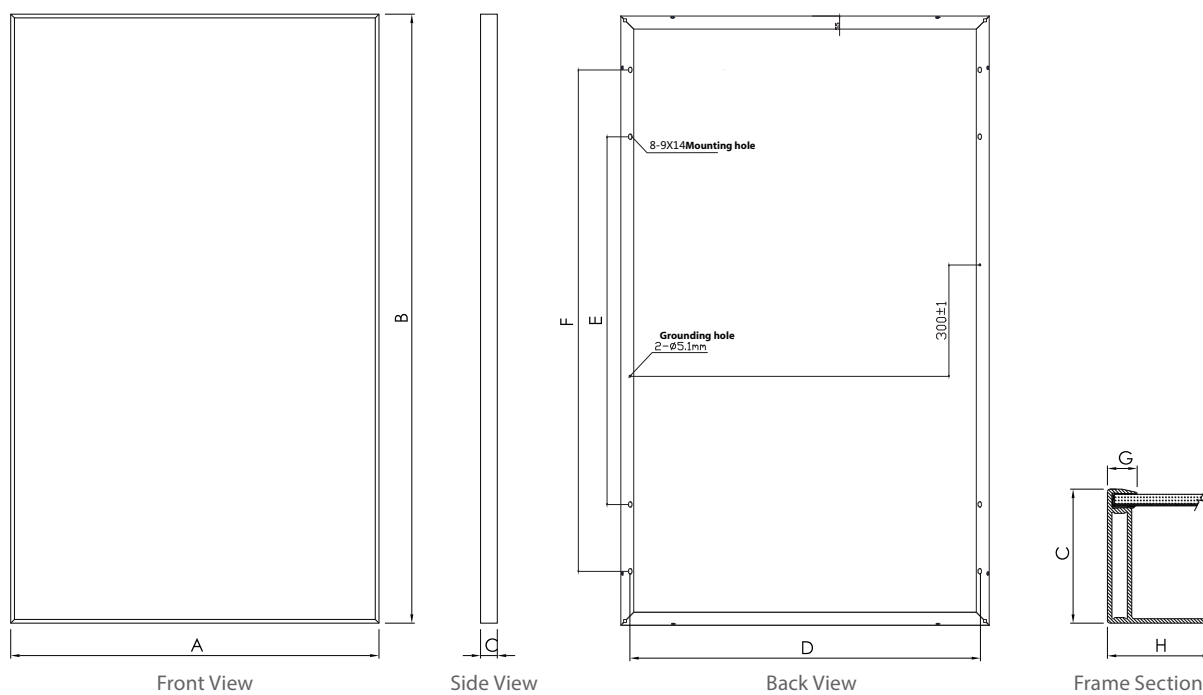

Figure 5

ELECTRICAL INSTALLATION

DC power generated by the photovoltaic system can be converted into AC power and fed into the grid. Policies on connecting renewable energy system to the grid vary from region to region. Consult senior system designer before designing the system. Generally, the system installation shall be formally approved by the local public sector.

General Installation

- Installation structure should be compatible with aluminum frame of module, in order to avoid galvanic corrosion. Any defects caused by such corrosion will void the warranty.
- Negative grounding is recommended during installation of Modules to prevent PID effect.
- Positive and negative part of the module should use the same type of connector for electrical connection.
- It is forbidden for non-professionals to open the lock nuts of the connector.
- Make sure that the connectors are clean, dry and fully connected (A click sound should be heard when fully connected), otherwise it may lead to electric arc sparks which will damage the connector or cause a fire.
- All electrical components should have ratings equal or greater to the system rating. Do not exceed the maximum of system voltage marked on the module label.
- Under normal conditions, a Module may produce more current and/or voltage than reported at standard test conditions. Accordingly, the values of ISC and Voc marked on the Module should be multiplied by a factor of 1.25 when determining component voltage ratings, current ratings, fuse sizes, and size of controls connected to the PV output.
- Completely cover the Modules with an opaque material to prevent electricity from being generated during disassembling the conductors.

- When connected in series, the maximum number of the Modules are determined by the system design, inverter type and environment. (shown in Figure 6).
- When connected in parallel, the current output is equal to the sum of each string's current (shown in Figure 7). Fuse is necessary for each module string. Please take reference to the local regulation. Recommended maximum parallel Modules configurations: Fuse rating/Isc+1.

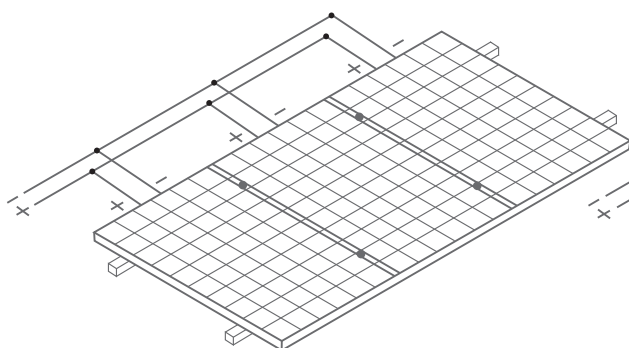

Figure 6

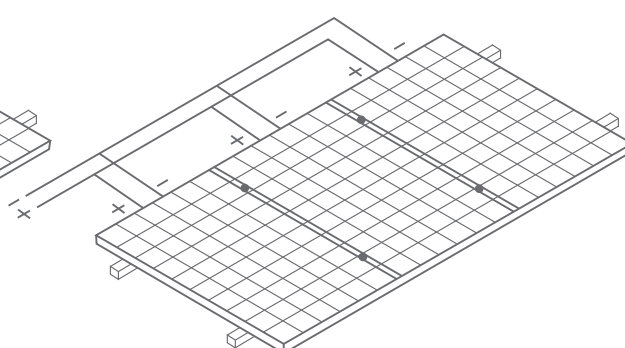

Figure 7

- Please refer to the local regulations to determine the system wire size, types and temperatures.
- The cross section of the cables and the capacity of the connectors must be selected to suit the maximum system short circuit current (The recommended section area for a single piece of Module is 4 mm^2 , and the recommended rated current for the connector is greater than 10A), otherwise the cables and connectors shall be overheated under large current. Caution: The maximal temperature of the cable is 85°C while the upper limited temperature of the connector is 105°C .
- Make sure the electric components such as the connectors and inverters are off-state during the installation.
- To reduce lightning damage, the loop area should be kept as small as possible when laying cables. It is recommended to use fuses in each string.

GROUNDING

- All the module frames and mounting structures shall be grounded according to regional and national electricity regulations. Use recommended hardware to connect grounding cables and fasten to the Module frames.
- While using the metal structure, make sure the surface of the system have been electroplated to keep a good conducting circuit.
- Use suitable grounding conductors to connect the Module frame to the mounting structure. This can achieve proper grounding effects.
- The grounding conductor must be connected to ground via an appropriate grounding electrode. It is recommended to use lugs to connect the grounding cables. If it is only mechanically connected to a grounded module without bolts and nuts, the mounting system should be grounded as well.

Grounding by lugs

First, peel the grounding cable to a proper length without damage to the metal core. Then insert the peeled cable into the lug, tighten the screw. As shown in Figure 8, connect the lug to the aluminum frame with stainless steel bolts and connection components. The recommended tightening torque for M3 bolts is 2.3 N·m.

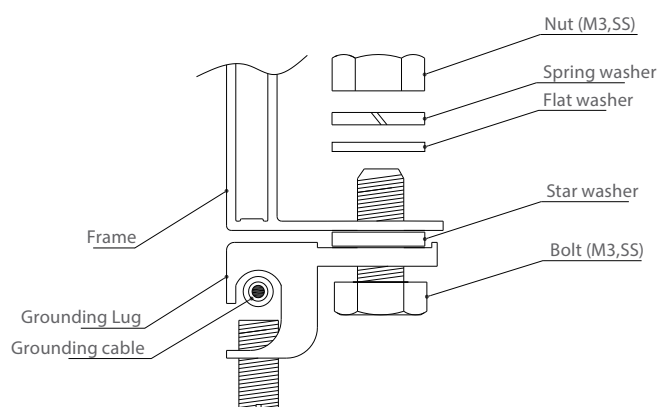

Figure 8

Grounding by cable

The grounding bolts must be made of stainless steel and be used in the specified grounding holes. First, make the M3.5 stainless steel bolt pass through the spring washer, flat washer, cup washer (copper conductor with a diameter of 2.1 mm) and star washer, and then insert through the grounding hole, flat washer and spring washer on the frame. Finally, tighten with a M3.5 nut. Caution: The upper limited temperature of the conductor is 85°C. As for the installation, refer to Figure 9.

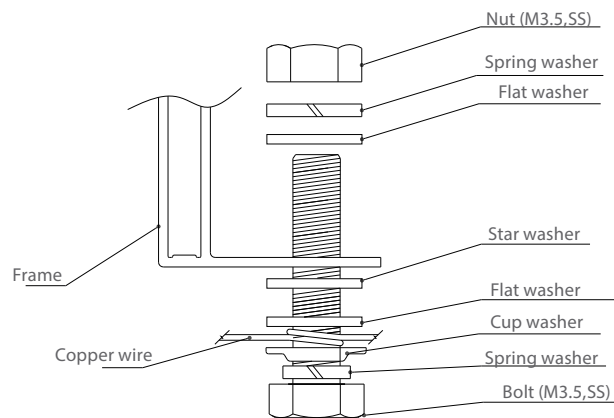

Figure 9

Bypass Diodes and Block Diodes

In a system with two or more Modules connected in series, if part of a Module is shaded while the other part is exposed to the sun, a very high reverse current will go through the cells which have been partly or entirely covered and it will cause overheat on the cells, which may damage the Module. Using bypass diodes can protect Modules from this kind of risk. There are bypass diodes in junction boxes, which can reduce the effects of partial shadows. Do not privately disassemble the junction box to replace the diodes, even when the diodes are broken. This should be processed by the professionals.

In a system with batteries, if the controller doesn't have the function of backswing protection, block diodes installed between the battery and the Module can prevent the reverse current from damaging the Module.

MAINTENANCE

Normally, the Modules don't need repair. Follow the maintenance methods below to ensure the best performance of the Modules:

- In most conditions, the normal rainwater can keep the module glass clean.
- Clean the glass surfaces with wet soft sponge or cloth if necessary. Use mild non-abrasive cleaning agent to remove stubborn dirt.
- Do not try to clean a Module with broken glass or perforated backsheet. It will cause serious electrical shock.
- Take a regular inspection on grounding, mechanical and electrical connections every 6 months. Make sure all the Module connectors are connected, clean and without damage or corrosion.
- When disassembling the connectors, must make sure all the components are working well; otherwise the connectors shall be replaced. Damage on the connector will cause water leakage. The tightening torque of the nut should be 1.5 N·m - 3 N·m.
- Use opaque material to completely cover the modules during repair to avoid electric shock. When exposed to the sunshine, the Modules will produce high voltage. The repair work must be carried out by professionals.



Warning: Shut down the system before any electric repair. Improper maintenance may cause electric shock or fire.



Supply the World with Clean Energy

Just Solar Co., Limited

Add: 1288 Kanghe Road, Xiuzhou District, Jiaxing City, Zhejiang Province, P.R. China

Tel: +86 3988 0300

Fax: +86 3988 5115

Web: www.jusolar.com